

• SPECIFICATION •

• 1460 - PHOENICIAN C-SPOUT SINK MIXER WITH FILTRATION

- Handcrafted in the UK
- 1/4 turn ceramic disc flow control
- Vernier insert for accurate handle alignment
- Supplied with white ceramic levers
- Single flow spout
- Supplied with 15mm check valves
- Ideally installed in equal pressure systems
- Stainless steel filter housing
- Swiss made Katadyn filter
- Flow regulated filtration for optimum performance
- Filters down to 0.2 microns
- Activated carbon core Reduces Chlorine, odour and bad taste
- Heavy metal removal
- Filter replacement every 6 months recommended

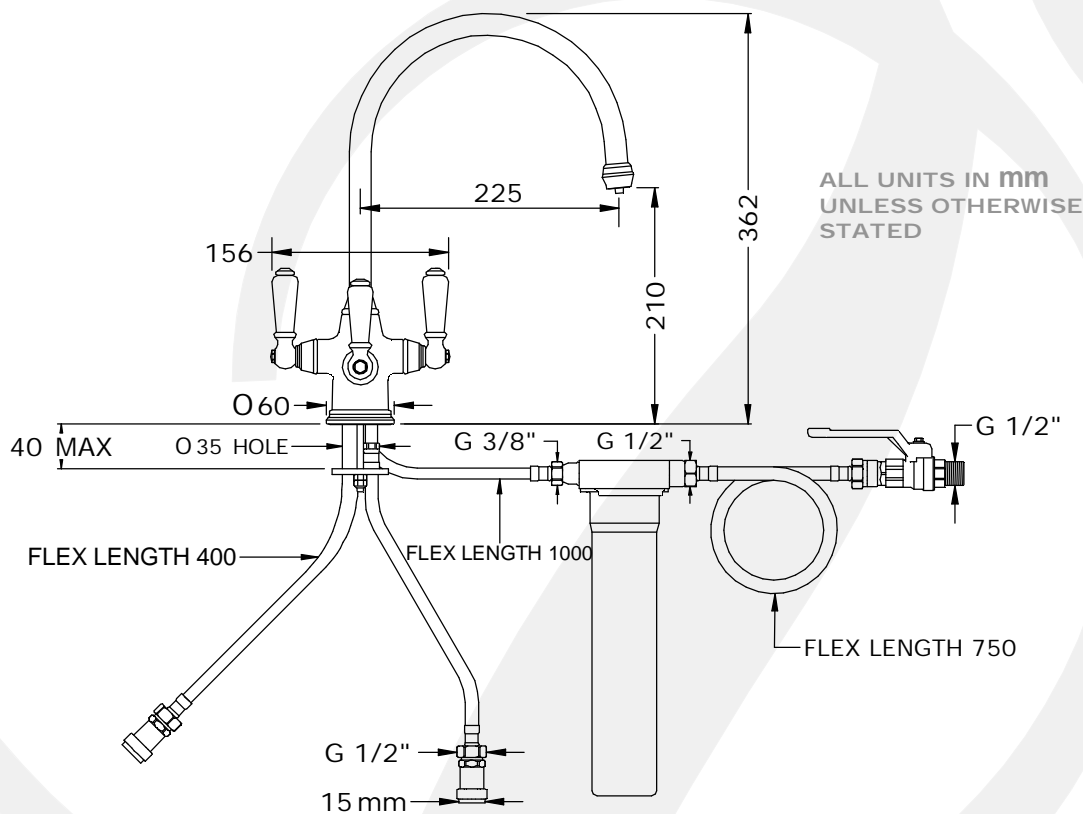

ALL UNITS IN MM
UNLESS OTHERWISE
STATED

Available Finishes:

- Chrome
- Nickel
- Pewter
- Polished Brass
- Satin Brass
- Aged Brass
- Gold
- English Bronze

• Temp Range:
Min 1°C / 34°F
Max 70°C / 158°F

• Recommended
Working Pressure:
Min 1bar / 15psi
Max 5bar / 75psi

• Packed Weight:
6.3 kg

Available Options:

- 6.6L/min regulated spout (Prefix AR.)
- Rinse version
- Black ceramic or Plated Levers
- Corian and Avonite Lever Finishes
- Matching soap dispensers

Flow Rates:

- 1 Bar: 10.0 L/Min
- 2 Bar: 15.4 L/Min
- 3 Bar: 17.2 L/Min