

N 70, Built-in freezer, 122.1 x 55.8 cm, soft close flat hinge
G17416CEO



COOKING PASSION SINCE 1877



The built-in freezer with automatic defrosting thanks to NoFrost.

- ✓ No Frost – No more defrosting your freezer.
- ✓ Individualize your drawers with various loading options to create the optimal fit for frozen goodies
- ✓ BigBox: An abundance of storage space even for large and bulky items.
- ✓ Softclose: When it reaches an angle of 20° the door softly closes itself.

Features

Technical Data

Energy Efficiency Class : E
Average annual energy consumption in kilowatt hour per year (kWh/a) : 206 kWh/annum
Sum of volume of frozen compartments : 130 l
Airborne acoustical noise emissions : 36 dB(A) re 1 pW
Airborne acoustical noise emission class : C
Thermometer freeze section : Digital
Light : No
Product category : Upright freezer
Construction type : Built-in
Door panel options : Not possible
Frost free system : Fridge and freezer
Height of the product : 1221 mm
Width of the appliance : 558 mm
Depth of the product : 545 mm
Dimensions of the packed product (HxWxD) : 1290 x 640 x 620 mm
Net weight : 47.657 kg
Gross weight : 50.9 kg
Connection rating : 120 W
Fuse protection : 10 A
Frequency : 50-60 Hz
Approval certificates : CE, VDE
Length of electrical supply cord : 230 cm
Door hinge : Left reversible
Storage Period in Event of Power Failure (h) : 9 h
Warning signal / malfunction : visual and audible
Lockable door : No
Number of drawers/baskets (Stck) : 4
Number of freezing flaps (Stck) : 1
EAN code : 4242004247647
Brand : Neff
Product name / Commercial code : G17416CEO
Product category : Upright freezer



4 242004 247647

N 70, Built-in freezer, 122.1 x 55.8 cm, soft close
flat hinge
G17416CEO



COOKING PASSION SINCE 1877

Features

Functions

- Fixed hinge

Design features

- Full frost free, never have to defrost ever again
- 7 segment electronic display
- 1 compressor/1 cold circuit
- SuperFreeze function with automatic deactivation
- FreshSense - constant temperature by intelligent sensor technology - Constant temperature control by intelligent sensor technology
- Freezer malfunction warning signal: optical, acoustical

Freezer Section

- 1 hinged freezer compartment
- 4 transparent freezer drawers, 1 bigbox

Technical Information

- Left hinged door, reversible
- Connection value 120 W
- 220 - 240 V

Dimension and installation

- Niche Dimensions: 122.5 cm H x 56 cm W x 55 cm D
- Dimensions: 122.1 cm H x 55.8 cm W x 54.5 cm D

Accessories

- ice cube tray

Included accessories

- KF1413S0, KF1413Z0

Country Specific Options

- Based on the results of the standard 24-hour test. Actual consumption depends on usage/position of the appliance.

Additional features

Performance and Consumption

- EU19_EEK_D: E
- Total Volume : 130 l
- Net 4* compartment volume : 130 l
- Freezing capacity 24h : 10 kg
- Annual Energy Consumption: 206 kWh/a
- Climate Class: SN-T
- Noise Level : 36 dB , EU19_Noise emission class_D: C

N 70, Built-in freezer, 122.1 x 55.8 cm, soft close
flat hinge
G17416CE0

Dimensioned drawings

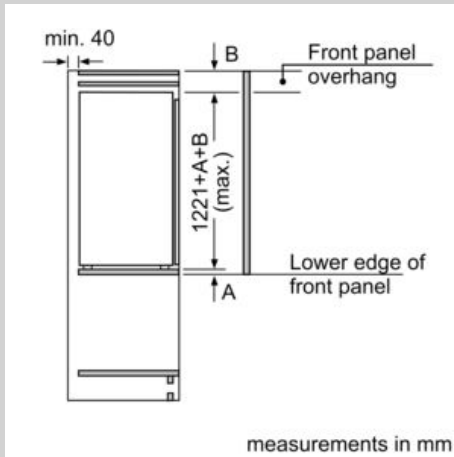
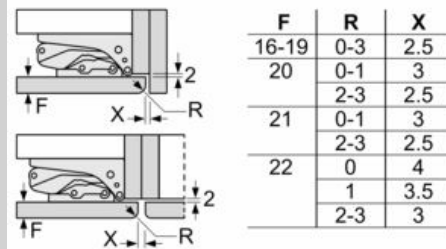
 measurements in mm
Recommended gap dimensions for flat hinges

The gap dimensions recommended in the table must be adhered to in order to ensure that appliance doors do not collide with anything when they are opened, and to avoid causing damage to kitchen units.

