

N 50, Built-in freezer, 71.2 x 55.8 cm, flat hinge
G1113FE0



COOKING PASSION SINCE 1877



This built-in freezer helps to defrost faster, comes with a malfunction warning signal and consumes very low energy only.

✓ LowFrost: Reduces frost in the freezer compartment for faster defrosting.

Features

Technical Data

Energy Efficiency Class : E
Average annual energy consumption in kilowatt hour per year (kWh/a) : 167 kWh/annum
Sum of volume of frozen compartments : 72 l
Airborne acoustical noise emissions : 36 dB
Airborne acoustical noise emission class : C
Thermometer freeze section : None
Light : No
Product category : Upright freezer
Construction type : Built-in
Door panel options : Not possible
Frost free system : No
Height of the product : 712 mm
Width of the appliance : 558 mm
Depth of the product : 545 mm
Dimensions of the packed product (HxWxD) : 790 x 640 x 620 mm
Net weight : 35.626 kg
Gross weight : 38.0 kg
Connection rating : 90 W
Fuse protection : 10 A
Frequency : 50 Hz
Approval certificates : CE, VDE
Length of electrical supply cord : 230 cm
Door hinge : Right reversible
Storage Period in Event of Power Failure (h) : 13 h
Defrost process : manual
Warning signal / malfunction : visual and audible
Lockable door : No
Number of drawers/baskets (Stck) : 3
Number of freezing flaps (Stck) : 0
EAN code : 4242004239628
Brand : Neff
Product name / Commercial code : G1113FE0
Product category : Upright freezer



4 242004 239628

N 50, Built-in freezer, 71.2 x 55.8 cm, flat hinge
G1113FEO



COOKING PASSION SINCE 1877

Features

Functions

- Fixed hinge
- Fixed hinge

Design features

- lowFrost freezer - less ice build up, faster defrosting
- SuperFreeze function with automatic deactivation
- Electronic control (LED chain)
- Freezer malfunction warning signal: optical, acoustical

Food freshness system

- 3 freezer drawers

Key features - Fridge section

- Right hinged door, reversible
- Connection value 90 W
- 220 - 240 V

Dimension and installation

- Dimensions: 71.2 cm H x 55.8 cm W x 54.5 cm D
- Niche Dimensions: 72 cm H x 56 cm W x 55 cm D

Key features - Freezer section

- ice cube tray

Included accessories

- KU1213Z0

Design features

Dimension and installation

Country Specific Options

- Based on the results of the standard 24-hour test. Actual consumption depends on usage/position of the appliance.

Performance and Consumption

Additional features

- Freezing possible in all freezer compartments
- Manual defrost freezer
- EU19_EEK_D: E
- Total Volume : 72 l
- Net 4* compartment volume : 72 l
- Freezing capacity 24h : 4.4 kg
- Annual Energy Consumption: 167 kWh/a
- Climate Class: SN-T
- Noise Level : 36 dB , EU19_Noise emission class_D: C
- Temperature rise time : EU19_Temperature rise time_D: 13 H

N 50, Built-in freezer, 71.2 x 55.8 cm, flat hinge
G1113FE0

Dimensioned drawings

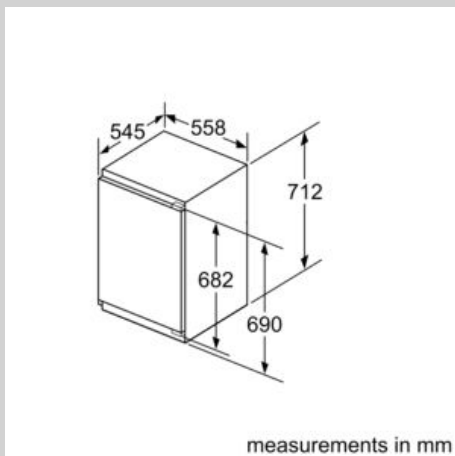
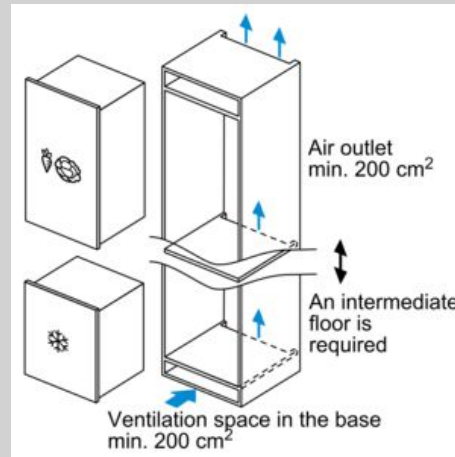
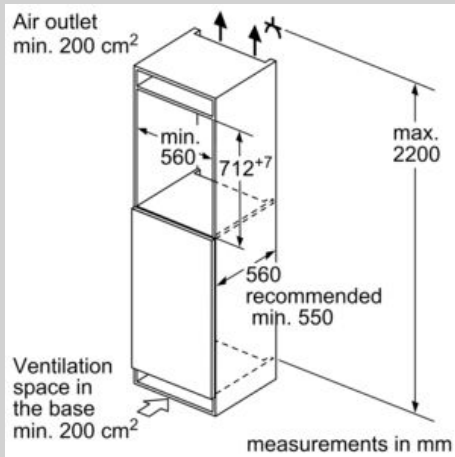

measurements in mm
Recommended gap dimensions for flat hinges

	F	R	X
16-19	0-3	2.5	
	20	0-1	3
21	2-3	2.5	
	21	0-1	3
22	2-3	2.5	
		0	4
		1	3.5
	2-3	3	

The gap dimensions recommended in the table must be adhered to in order to ensure that appliance doors do not collide with anything when they are opened, and to avoid causing damage to kitchen units.

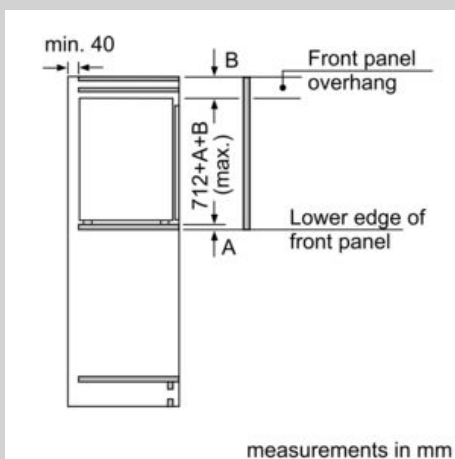

Maximal permissible weight of the unit fronts

Fitted unit fronts that exceed the permissible weight may cause damage and result in functional impairment of the hinges

Δ Weight

A: Appliance door height including hinges in mm

B: Undamped hinge, unit front in kg

C: Damped hinge, unit front in kg

	A	B	C
1500-1750	22	22	22
720-1400	19	19	19
A1	15	19	
A2	15	19	